

KINTEK® | **Gait**
COMPONENTI INNOVATIVI TECNOMECCANICI
TOGETHER WE BRAND QUALITY!

KINTEK SRL

10079 MAPPANO (TO) - ITALIA
VIA GORETTA 88/G
TEL. +39 011 9968065, FAX +39 011 9965662
INFO@KINTEK.IT

COD. FISC. / PARTITA IVA: 08746040016
CAP. SOC.: EURO 179.850,00
REA: 997323 - R.I. UFF. TO: 08746040016
CODICE UNIVOCO: M5UXCR1

KINTEK.IT



KINTEK®

GOLDEN
CAMPAIGN 2024



Gait

MANDRINI IDRAULICI PER UTENSILI ATTACCO CILINDRICO

MANDRINS HYDRO-EXPANSIBLES POUR OUTILS A QUEUE CYLINDRIQUE

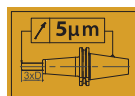
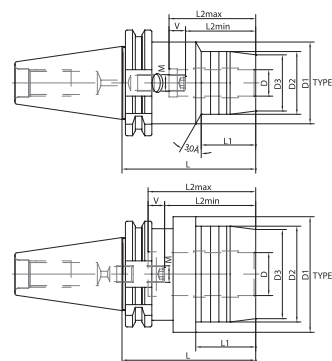

DIN69871 AD

	CODE N.	PRICE	DESCRIPTION	ISO	D	D1	D2	D3	L	L1	L2 min	L2 max	V	M	TYPE	G2,5 25000
SK 40	252-11305	232,00	TC40-HC6-80,5	40	6	50	28	25	80,5	44	27,5	37,5	10	M5x0,8	A	•
	252-11307	232,00	TC40-HC8-80,5	40	8	50	30	27	80,5	44	27,5	37,5	10	M6x1	A	•
	252-11309	228,00	TC40-HC10-80,5	40	10	50	32	29	80,5	44	32,5	42,5	10	M6x1	A	•
	252-11311	228,00	TC40-HC12-80,5	40	12	50	34	31	80,5	44	37,5	47,5	10	M6x1	A	•
	252-11327	228,00	TC40-HC14-80,5	40	14	50	36	33	80,5	44	37,5	47,5	10	M6x1	A	•
	252-11313	228,00	TC40-HC16-80,5	40	16	50	38	35	80,5	48	42,5	52,5	10	M8x1	A	•
	252-11328	228,00	TC40-HC18-80,5	40	18	50	41	38	80,5	30	42,5	52,5	10	M8x1	A	•
	* 252-11325	184,00	TC40-G20CS-64,5	40	20	-	49,5	40	64,5	45,5	42,5	52,5	10	M8x1	A	•
	252-11315	228,00	TC40-HC20-80,5	40	20	50	43	40	80,5	48	42,5	52,5	10	M8x1	A	•
	252-11317	228,00	TC40-HC25-80,5	40	25	66	57	53	80,5	26	51	61	10	M16x1	B	•
252-11318	228,00	TC40-HC32-80,5	40	32	80	63	60	80,5	26	55	65	10	M16x1	B	•	

*COMPACT VERSION

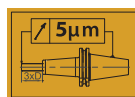
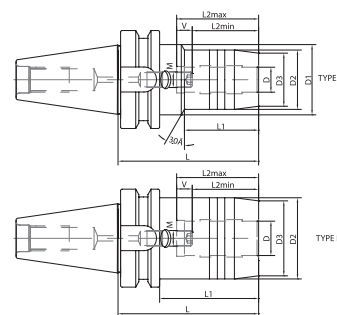

MAS403/BT AD

	CODE N.	PRICE	DESCRIPTION	ISO	D	D1	D2	D3	L	L1	L2 min	L2 max	V	M	TYPE	G2,5 25000
BT 40	252-11422	232,00	BT40-HC6-90	40	6	50	28	25	90	44	27,5	37,5	10	M5x0,8	A	•
	252-11423	232,00	BT40-HC8-90	40	8	50	30	27	90	39	27,5	37,5	10	M6x1	A	•
	252-11424	228,00	BT40-HC10-90	40	10	50	32	29	90	44	32,5	42,5	10	M6x1	A	•
	252-11425	228,00	BT40-HC12-90	40	12	50	34	31	90	44	37,5	47,5	10	M6x1	A	•
	252-11426	228,00	BT40-HC14-90	40	14	50	36	33	90	44	37,5	47,5	10	M6x1	A	•
	252-11427	228,00	BT40-HC16-90	40	16	50	38	35	90	48	42,5	52,5	10	M8x1	A	•
	252-11428	228,00	BT40-HC18-90	40	18	50	41	38	90	48	42,5	52,5	10	M8x1	A	•
	* 252-11443	184,00	BT40-G20CS-72,5	40	20	-	49,5	40	72,5	45,5	42,5	52,5	10	M8x1	B	•
	252-11429	228,00	BT40-HC20-90	40	20	50	43	40	90	48	42,5	52,5	10	M8x1	A	•
	252-11483	228,00	BT40-HC25-100	40	25	-	57	53	100	73	51	61	10	M16x1	B	•
252-11485	228,00	BT40-HC32-105	40	32	-	63	58	105	-	55	65	10	M16x1	B	•	

*COMPACT VERSION

MANDRINI IDRAULICI PER UTENSILI ATTACCO CILINDRICO MANDRINS HYDRO-EXPANSIBLES POUR OUTILS A QUEUE CYLINDRIQUE

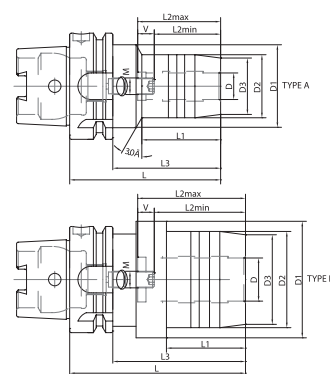
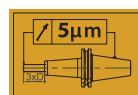

DIN69893 A

	CODE N.	PRICE	DESCRIPTION	HSK	D	D1	D2	D3	L	L1	L3	L2 min	L2 max	V	M	TYPE	G2,5 25000
HSK 63	252-11737	300,00	HSK63A-HC6-70	63	6	50	28	25	70	24	44	27,5	37,5	10	M5x0,8	A	•
	252-11738	300,00	HSK63A-HC8-70	63	8	50	30	27	70	24	44	27,5	37,5	10	M6x1	A	•
	252-11739	272,00	HSK63A-HC10-80	63	10	50	32	29	80	35	54	32,5	42,5	10	M6x1	A	•
	252-11740	272,00	HSK63A-HC12-85	63	12	50	34	31	85	40	59	37,5	47,5	10	M6x1	A	•
	252-11741	272,00	HSK63A-HC14-85	63	14	50	36	33	85	40	59	37,5	47,5	10	M6x1	A	•
	252-11742	272,00	HSK63A-HC16-90	63	16	50	38	35	90	46	64	42,5	52,5	10	M8x1	A	•
	*252-11744	272,00	HSK63A-HC20-90	63	20	50	43	40	90	48	64	42,5	52,5	10	M8x1	A	•
	252-11746	272,00	HSK63A-HC32-125	63	32	75	63	58	125	63	99	55	65	10	M16x1	B	•

*COMPACT VERSION

KIT IDRAULICO SET HYDRAULICO



CASSETTA CORREDO:
1 MANDRINO "IDRAULICO"
+ 1 SERIE PINZE + 1 CHIAVE

KIT BOX:
1 HYDRAULIC CHUCK
+ 1 COLLETS KIT + 1 WRENCH

	CODICE ORDINAZIONE ORDER CODE	PRICE	COMPOSIZIONE COMPOSITION
ISO 40	KIT TC40 G20	407,00	N°1 TC40 H64,5 G20-WO + n°5 pinze GX20: Ø6,8,10,12,16
	KIT TC40 G32	555,00	N°1 TC40 H80,5 G32-WO + n°7 pinze GX32: Ø10,12,14,16,18,20,25
ISO 40	KIT BT40 G20	407,00	N°1 BT40 H72,5 G20-WO + n°5 pinze GX20: Ø6,8,10,12,16
	KIT BT40 G32	555,00	N°1 BT40 H105 G32-WO + n°7 pinze GX32: Ø10,12,14,16,18,20,25
HSK	KIT HSK63A G20	484,00	N°1 HSK63A H90 G20 + n°5 pinze GX20: Ø6,8,10,12,16
	KIT HSK63A G32	588,00	N°1 HSK63A H125 G32 + n°7 pinze GX32: Ø10,12,14,16,18,20,25

MANDRINI A FORTE SERRAGGIO

MANDRINS A FORT SERRAGE

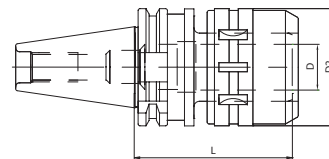

DIN 69871 AD

CODE N.	PRICE	DESCRIPTION	ISO	D	D2	L	G6,3 12000 RPM
214-01308	136,00	TC40H90C20	40	20	54	90	•
214-01301	136,00	TC40H105C20	40	20	54	105	•
214-01302	148,00	TC40H105C32	40	32	72	105	•
214-01304	160,00	TC50H105C20	50	20	54	105	•
214-01305	175,00	TC50H105C32	50	32	72	105	•
214-01306	203,00	TC50H135C32	50	32	72	135	•

FORNITI CON CHIAVE INCLUSA - SUPPLIED WITH WRENCH

MILLING CHUCK (diameter)	SPECIFICATION (DIN)	TOLERANCE (Taper shank)	RUN-OUT (3xD)	CLAMPING TORQUE
C20	AT3	TC40 (0~+0,003)	0~0,01	980M.m (100 Kgf.m)
C32		TC50 (0~+0,004)		3430M.m (350 Kgf.m)

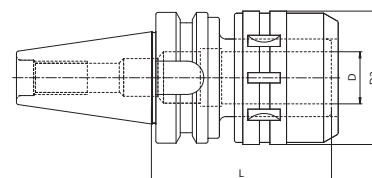
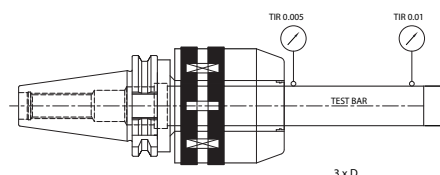

JIS-B 6339 MAS 403/BT AD

CODE N.	PRICE	DESCRIPTION	ISO	D	D2	L	G6,3 12000 RPM
214-01508	136,00	BT40H80C20	40	20	54	80	•
214-01501	136,00	BT40H105C20	40	20	54	105	•
214-01502	148,00	BT40H105C32	40	32	72	105	•
214-01504	148,00	BT50H105C20	50	20	54	105	•
214-01505	176,00	BT50H105C32	50	32	72	105	•
214-01506	203,00	BT50H135C32	50	32	72	135	•

FORNITI CON CHIAVE INCLUSA - SUPPLIED WITH WRENCH

MILLING CHUCK (diameter)	SPECIFICATION (DIN)	TOLERANCE (Taper shank)	RUN-OUT (3xD)	CLAMPING TORQUE
C20	AT3	BT40 (0~+0,003)	0~0,01	980M.m (100 Kgf.m)
C32		BT50 (0~+0,004)		3430M.m (350 Kgf.m)

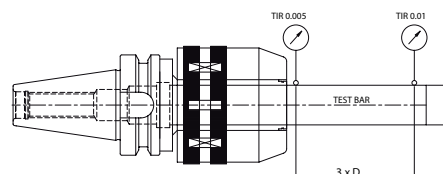

MANDRINI A FORTE SERRAGGIO MANDRINS A FORT SERRAGE

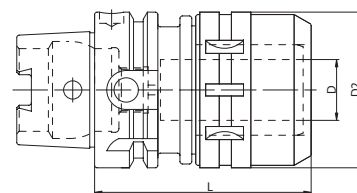

DIN 69893 A+C

HSK	CODE N.	PRICE	DESCRIPTION	D	D2	L	G6,3 12000
63	214-01701	300,00	HSK63AH105C20	20	54	105	•
63	214-01702	300,00	HSK63AH130C32	32	72	130	•

FORNITI CON CHIAVE INCLUSA - SUPPLIED WITH WRENCH

MILLING CHUCK (diameter)	SPECIFICATION (DIN)	RUN-OUT (3xD)	CLAMPING TORQUE
C20	DIN 69893 A	0~0,01	980M.m (100 Kgf.m)
C32	HSK40A		3430M.m (350 Kgf.m)
-	HSK50A		-
-	HSK63A		-
-	HSK100A	-	-

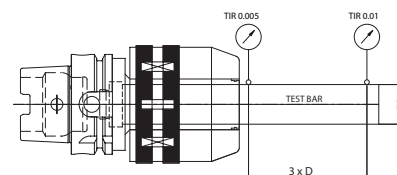

KIT FORTE SERRAGGIO MILLING CHUCK KITS



CASSETTA CORREDO:
1 MANDRINO FORTE SERRAGGIO
+ 1 SERIE PINZE + 1 CHIAVE

KIT BOX:
1 MILLING CHUCK
+ 1 COLLETS KIT + 1 WRENCH

	CODICE ORDINAZIONE ORDER CODE	PRICE	COMPOSIZIONE COMPOSITION
ISO 40	KIT TC40 C20	188,00	N°1 TC 40 L90 C20 + n°5 pinze K20: Ø6,8,10,12,16
	KIT TC40 C32	234,00	N°1 TC 40 L105 C32 + n°7 pinze K32: Ø6,8,10,12,16,20,25
ISO 40	KIT TC50 C20	214,00	N°1 TC 50 L105 C20 + n°5 pinze K20: Ø6,8,10,12,16
	KIT TC50 C32	260,00	N°1 TC 50 L105 C32 + n°7 pinze K32: Ø6,8,10,12,16,20,25
ISO 40	KIT BT40 C20	188,00	N°1 BT40 L80 C20 + n°5 pinze K20: Ø6,8,10,12,16
	KIT BT40 C32	234,00	N°1 BT40 L80 C32 + n°7 pinze K32: Ø6,8,10,12,16,20,25
ISO 40	KIT BT50 C20	214,00	N°1 BT 50 L105 C20 + n°5 pinze K20: Ø6,8,10,12,16
	KIT BT50 C32	275,00	N°1 BT 50 L105 C32 + n°7 pinze K32: Ø6,8,10,12,16,20,25
HSK	KIT HSK63A C20	338,00	N° HSK63AH105C20 + n°5 pinze K20: Ø6,8,10,12,16 + chiave
	KIT HSK63A C32	370,00	N° HSK63AH120C32 + n°7 pinze K32: Ø6,8,10,12,16,20,25 + chiave

PORTAUTENSILE MOTORIZZATO ASSIALE AXIAL DRILLING AND MILLING HEAD

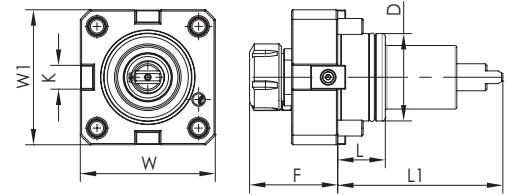

BMT

CODE N.	PRICE	BMT	ER	D	F	K	L	L1	W	W1	MAX: SPEED (Rpm)	I	MAX: TORQUE Nm	INTERNAL COOLING
124-04502	915,00	45	ER25	45	67,6	15	40	84	78,5	75	6000	1:1	50	yes
124-05501	850,00	55	ER25	55	71	15	30	104	85	85	6000	1:1	50	no
124-06509	940,00	55	ER25	55	71	15	30	104	85	85	6000	1:1	50	yes
124-06501	1.020,00	65	ER32	65	75	18	32	112	94	94	6000	1:1	70	no
124-06508	1.100,00	65	ER32	65	75	18	32	112	94	94	6000	1:1	70	yes

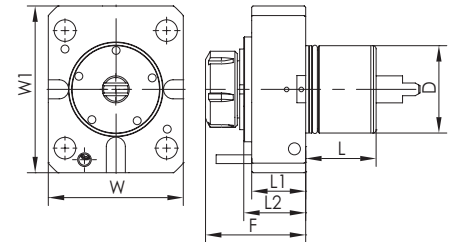

MORI SEIKI NL2000

CODE N.	PRICE	ER	D	F	L	L1	L2	W	W1	TORQUE (Nm)	Nmax (rpm)	I	INTERNAL COOLING	P (bar)
124-06003	1.345,00	ER32	60	89	53	48,5	58	108	130	70	6000	1:1	yes	20

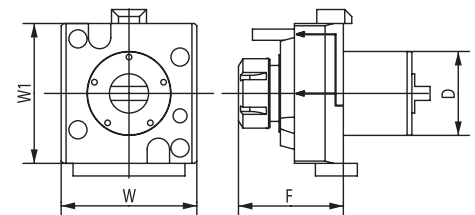
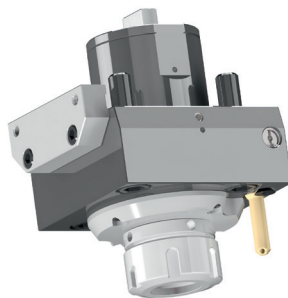

MORI SEIKI NL2000

CODE N.	PRICE	D	ER	INTERNAL COOLING	F	W	W1	TORQUE (Nm)	Nmax (rpm)	RATIO	P (bar)
124-06005	1.360,00	60	ER32	no	87	97	100	70	6000	1:1	-
124-06006	1.525,00	60	ER32	yes	87	97	100	70	6000	1:1	20

PORTAUTENSILE MOTORIZZATO RADIALE RADIAL DRILLING AND MILLING HEAD

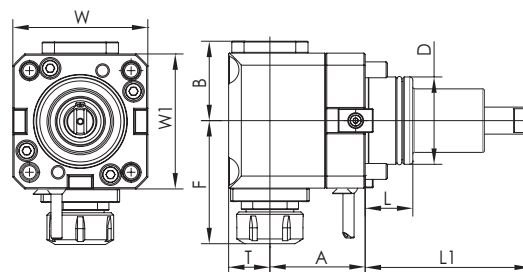
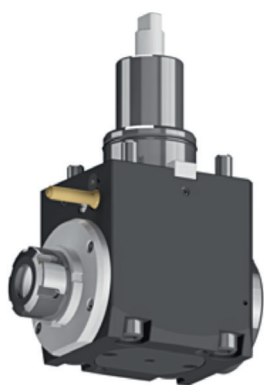

BMT

CODE N.	PRICE	BMT	ER	D	A	B	F	L	L1	T	W	W1	MAX: SPEED (Rpm)	I	MAX: TORQUE Nm	INTERNAL COOLING	P BAR
124-04504	1.575,00	45	ER25	45	65	57	97,6	40	84	36,5	75	83	6000	1:1	50	yes	20
124-05502	1.625,00	55	ER25	55	70	57	98	30	104	36,5	85	98	6000	1:1	50	no	-
124-06510	1.715,00	55	ER25	55	70	57	98	30	104	36,5	85	98	6000	1:1	50	yes	20
124-05511	1.625,00	55	ER25	55	85	57	98	30	104	36,5	85	98	6000	1:1	50	no	-
124-05512	1.715,00	55	ER25	55	85	57	98	30	104	36,5	85	98	6000	1:1	50	yes	20
124-06502	1.775,00	65	ER32	65	72	59	111	32	112	38	94	100	6000	1:1	70	no	-
124-06512	1.850,00	65	ER32	65	72	59	111	32	112	38	94	100	6000	1:1	70	yes	20
124-06513	1.950,00	65	ER32	65	100	59	111	32	112	38	94	100	6000	1:1	70	no	-
124-06514	2.025,00	65	ER32	65	100	59	111	32	112	38	94	100	6000	1:1	70	yes	20

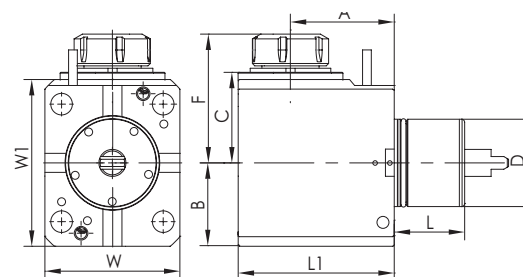
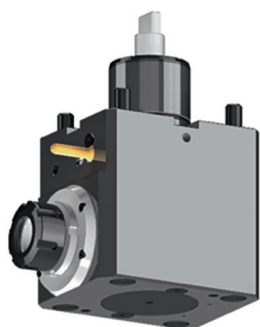

MORI SEIKI NL2000

CODE N.	PRICE	ER	D	F	L	L1	A	B	C	W	W1	TORQUE (Nm)	Nmax (rpm)	I	INTERNAL COOLING	P (bar)
124-06004	2.000,00	ER32	60	107	53	128	90	65	78	108	130	70	6000	1:1	yes	20

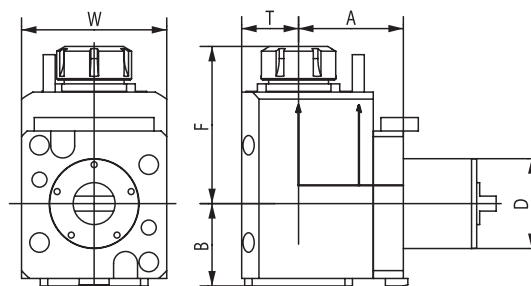
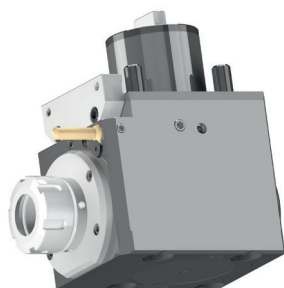

MORI SEIKI NL2000

CODE N.	PRICE	D	ER	INTERNAL COOLING	DIRECTION	A	B	F	T	W	TORQUE (Nm)	Nmax (rpm)	RATIO	P (bar)
124-06007	2.050,00	60	ER32	no	right/left	70	59	111	38	94	70	6000	1:1	-
124-06008	2.175,00	60	ER32	yes	right/left	70	59	111	38	94	70	6000	1:1	20

MANDRINI PORTAFRESE TIPO WELDON

END MILL HOLDERS WELDON

SHORT

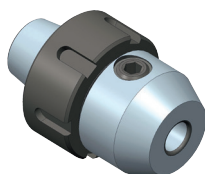

CODE N.	DESCRIPTION	D	L	PRICE
213-16707	ER25H35WE06	6	35	160,00
213-16709	ER25H39WE10	10	39	160,00
213-16710	ER25H43WE12	12	43	160,00
213-16701	ER32H35WE06	6	35	160,00
213-16702	ER32H35WE08	8	35	160,00
213-16703	ER32H39WE10	10	39	160,00
213-16704	ER32H43WE12	12	43	160,00

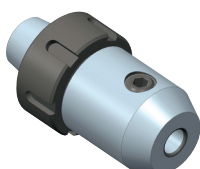
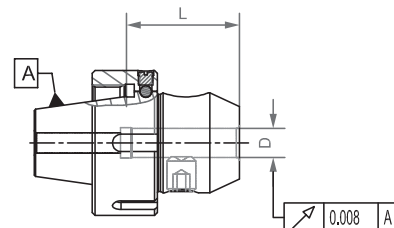

CODE N.	DESCRIPTION	D	L	PRICE
213-16715	ER32H55WE06	6	55	175,00
213-16717	ER32H59WE10	10	59	175,00
213-16718	ER32H63WE12	12	63	175,00
213-16720	ER32H65WE16	16	65	175,00

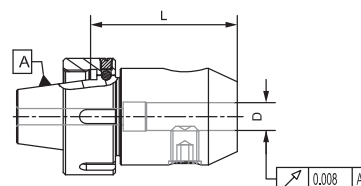

MANDRINI PORTAFRESE A TRASCINAMENTO FISSO

FACE MILL HOLDERS-TENONS DRIVE

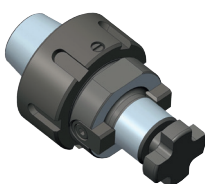

CODE N.	DESCRIPTION	D	L1	L2	PRICE
216-76704	ER25H22D16	16	22	17	155,00
216-76705	ER25H24D22	22	24	19	155,00
216-76701	ER32H22D16	16	22	17	163,00
216-76702	ER32H24D22	22	24	19	163,00
216-76703	ER32H26D27	27	26	21	170,00

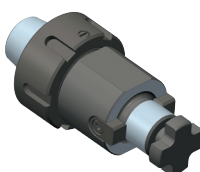
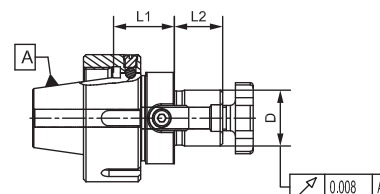

CODE N.	DESCRIPTION	D	L1	L2	PRICE
216-76708	ER32H42D16	16	42	17	170,00
216-76709	ER32H44D22	22	44	19	170,00

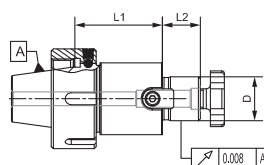

MANDRINI PORTAPINZA TIPO ER

ER COLLET CHUCK

SHORT

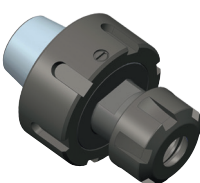

CODE N.	DESCRIPTION	ER	D	D2	L	PRICE
214-36704	ER32H41ER16	16	32	22	41	165,00
214-36705	ER32H43ER20	20	35	25	43	165,00
214-36706	ER32H45ER25	25	42	32	45	165,00
214-36707	ER32H48ER32	32	50	40	48	165,00

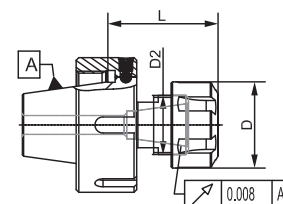

PINZE DI CHIUSURA A CONO SEMPLICE

SINGLE CONE CLAMPING COLLETS

DIN 6343

TONDA
ROUND



ART.	A	B	L	α	\varnothing MAX	EINHELTS	PRICE
G0722	15,0	21,0	64,0	16°	12,0	120E	15,00
G0937	20,0	28,0	67,0	16°	16,0	138E	17,00
G0717	25,0	35,0	77,0	16°	20,0	145E	19,00
G0713	28,0	38,0	70,0	15°	23,0	148E	17,00
G0701	32,0	45,0	75,0	15°	26,0	161E	17,00
G0764	35,0	48,0	80,0	15°	30,0	163E	30,00
G0970	37,0	47,0	92,0	16°	32,0	1536E	36,00
G0709	48,0	60,0	94,0	15°	42,0	173E	32,00
G0759	66,0	84,0	110,0	15°	60,0	185E	57,00

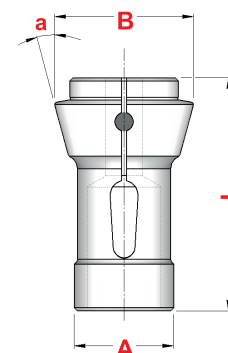

NELLE PINZE TONDE, L'ARTICOLO SI RIFERISCE ALL'ESECUZIONE CON INTERNO RIGATO.
FOR ROUND COLLETS, THE ARTICLE REFERS TO THE EXECUTION WITH GROOVED INSIDE.

IN CASO DI ORDINE AGGIUNGERE AL CODICE IL DIAMETRO RICHIESTO: ES. 0721 D02 PER D.02
IN CASE OF ORDER PLEASE ADD TO THE CODE THE REQUESTED DIAMETER E.G. 0721 D02 FOR D.02

PINZE DI EMERGENZA LAVORABILI

EMERGENCY COLLETS

DIN 6343

TONDA
ROUND



ART.	A	B	L	α	EINHELTS	PRICE
G0717 EC	25,0	35,0	77,0	16°	145E	33,00
G0701 EC	32,0	45,0	75,0	15°	161E	34,00
G0970 EC	37,0	47,0	92,0	16°	1536E	57,00
G0709 EC	48,0	60,0	94,0	15°	173E	54,00
G2424 EC	58,0	70,0	94,0	15°	177E	72,00
G0759 EC	66,0	84,0	110,0	15°	185E	74,00

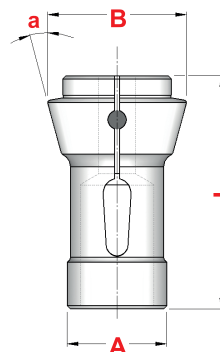

LE PINZE DI EMERGENZA POSSONO ESSERE FINITE DAL CLIENTE CON IL DIAMETRO DI PRESA O LA SAGOMA DESIDERATA GRAZIE ALLA PARTE ANTERIORE LAVORABILE. LA FORNITURA COMPRENDE LE SPINE DI REGISTRO UTILI PER IL POSIZIONAMENTO NEL MANDRINO.

EMERGENCY COLLETS CAN BE FINISHED BY THE CUSTOMER WITH THE DIAMETER OR THE DESIRED SHAPE THANKS TO THE WORKABLE FRONT. THE SUPPLY INCLUDES THE REGISTER PINS USEFUL FOR POSITIONING IN THE SPINDLE.

MORSA AUTOCENTRANTE A 5 ASSI MRC48 X 78

LA MORSA È ADATTA PER SISTEMI DI BLOCCAGGIO A PUNTO ZERO CON INTERASSE 52 MM. PUÒ ESSERE UTILIZZATA PER PARTICOLARI GREZZI CON GRIP 3 MM. E SUPERFICI LISCE CON GANASCIA RETTIFICATA. LE GANASCE SONO REVERSIBILI E PERMETTONO DI RAGGIUNGERE UN CAMPO DI SERRAGGIO PIÙ AMPIO. DISPONIBILI ACCESSORI E RICAMBI.

5-AXIS CENTRING VICE MRC48 X 78

SUITABLE FOR ZERO POINT CLAMPING SYSTEMS WITH 52 GRID. CAN BE USED FOR PRE-PRESSED PARTS OR WITH SMOOTH SURFACES. REVERSIBLE JAWS. ACCESSORIES AND SPARE PARTS AVAILABLE. JAWS CAN BE REVERSED FOR A WIDER CLAMPING RANGE.



NEW

MRC48 X 78 - MRC48 X 118 - MRC48 X 158	PRICE	559,00	616,00	743,00
LARGHEZZA GANASCE / JAW WIDTH	mm	48,5	48,5	48,5
LUNGHEZZA CORPO / BODY LENGTH	mm	78	118	158
GAMMA DI SERRAGGIO NORMALE - GANASCIA ROVESCIATA CLAMPING RANGE NORMAL REVERSED JAW	mm	6-40/30-60	6-80/30-100	6-120/30-140
SISTEMA DI SERRAGGIO A PUNTO ZERO / ZERO POINT CLAMPING SYSTEM	mm	□ 52	□ 52	□ 52
DIAMETRO DEL BULLONE A PUNTO ZERO / ZERO POINT BOLT DIAMETER	mm	∅ 16	∅ 16	∅ 16
COPPIA DI SERRAGGIO (MAX) / TIGHTENING TORQUE (MAX)	Nm	30	30	30
FORZA DI SERRAGGIO / CLAMPING FORCE	kN	6	6	6
PRECISIONE DI CENTRATURA / CENTRING ACCURACY	mm	± 0,02	± 0,02	± 0,02

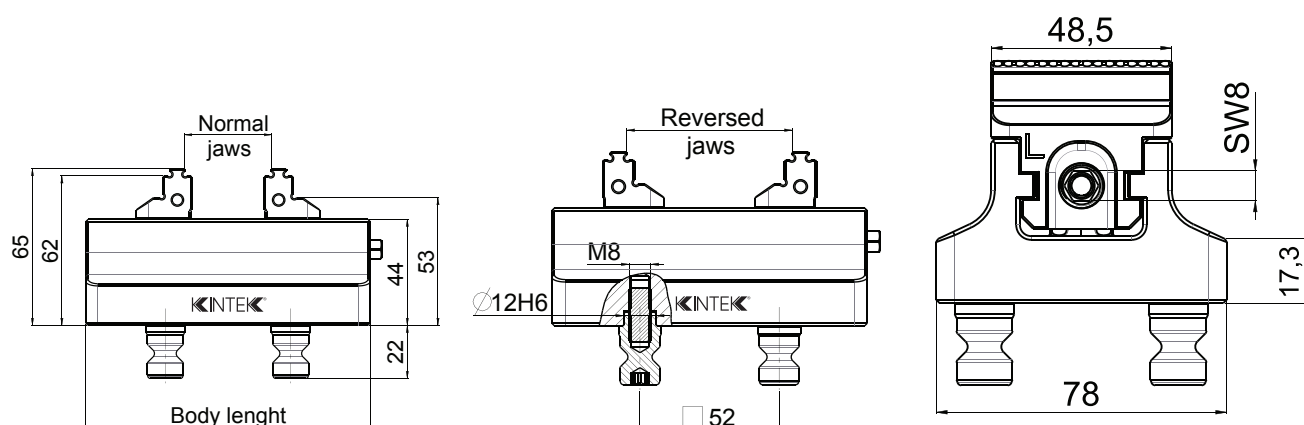

MORSA AUTOCENTRANTE A 5 ASSI MRC78 X 110

LA MORSA È ADATTA PER SISTEMI DI BLOCCAGGIO A PUNTO ZERO CON INTERASSE 52 MM. PUÒ ESSERE UTILIZZATA PER PARTICOLARI GREZZI CON GRIP 3 MM. E SUPERFICI LISCE CON GANASCE RETTIFICATE. LE GANASCE SONO REVERSIBILI E PERMETTONO DI RAGGIUNGERE UN CAMPO DI SERRAGGIO PIÙ AMPIO. DISPONIBILI ACCESSORI E RICAMBI.

5-AXIS CENTRING VICE MRC78 X110

SUITABLE FOR ZERO POINT CLAMPING SYSTEMS WITH 52 GRID. CAN BE USED FOR PRE-PRESSED PARTS OR WITH SMOOTH SURFACES. REVERSIBLE JAWS. ACCESSORIES AND SPARE PARTS AVAILABLE. JAWS CAN BE REVERSED FOR A WIDER CLAMPING RANGE.



MRC78 X 110	PRICE	672,00	COPPIA DI SERRAGGIO [kN] / TIGHTENING TORQUE [kN]
LARGHEZZA GANASCE / JAW WIDTH	mm	78,5	100
LUNGHEZZA CORPO / BODY LENGTH	mm	110	90
GAMMA DI SERRAGGIO / CLAMPING RANGE	mm	0-90	80
SISTEMA DI SERRAGGIO A PUNTO ZERO / ZERO POINT CLAMPING SYSTEM	mm	□ 52	70
DIAMETRO DEL BULLONE A PUNTO ZERO / ZERO POINT BOLT DIAMETER	mm	Ø 16	60
COPPIA DI SERRAGGIO (MAX) / TIGHTENING TORQUE (MAX)	Nm	70	50
FORZA DI SERRAGGIO / CLAMPING FORCE	kN	14	40
PRECISIONE DI CENTRATURA / CENTRING ACCURACY	mm	± 0,02	30
			20
			10

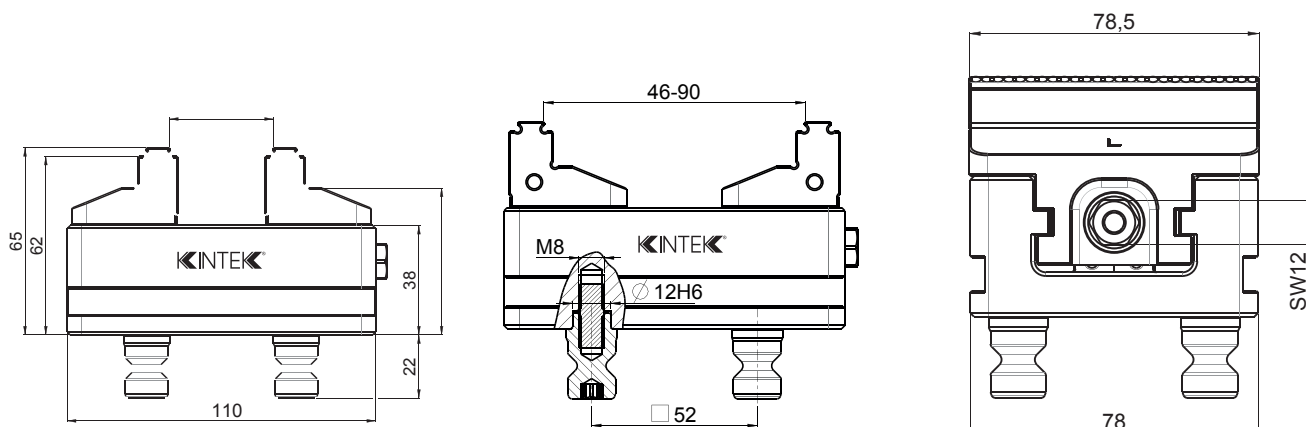
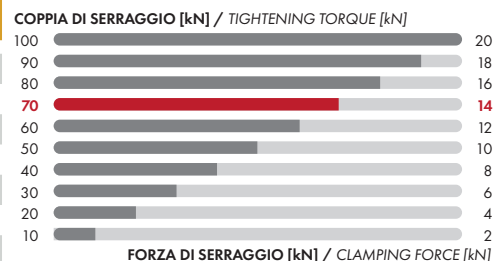

MORSA AUTOCENTRANTE A 5 ASSI MRC78 X 145

LA MORSA È ADATTA PER SISTEMI DI BLOCCAGGIO A PUNTO ZERO CON INTERASSE 52 MM.
 PUÒ ESSERE UTILIZZATA PER PARTICOLARI GREZZI CON GRIP 3 MM. E SUPERFICI LISCE CON GANASCIA RETTIFICATA.
 LE GANASCE SONO REVERSIBILI E PERMETTONO DI RAGGIUNGERE UN CAMPO DI SERRAGGIO PIÙ AMPIO.
 DISPONIBILI ACCESSORI E RICAMBI.

5-AXIS CENTRING VICE MRC78 X 145

SUITABLE FOR ZERO POINT CLAMPING SYSTEMS WITH 52 GRID. CAN BE USED FOR PRE-PRESSED PARTS OR WITH SMOOTH SURFACES. REVERSIBLE JAWS.
 ACCESSORIES AND SPARE PARTS AVAILABLE. JAWS CAN BE REVERSED FOR A WIDER CLAMPING RANGE.

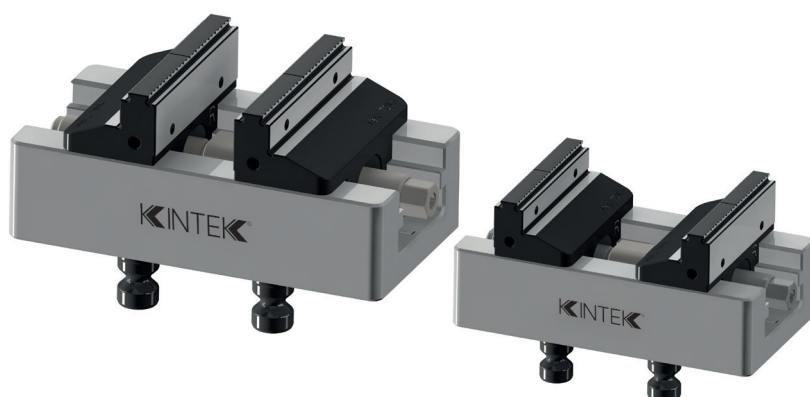

MRC78 X 145	PRICE	656,00	COPPIA DI SERRAGGIO [kN] / TIGHTENING TORQUE [kN]
LARGHEZZA GANASCE / JAW WIDTH	mm	78,5	100
LUNGHEZZA CORPO / BODY LENGTH	mm	145	90
GAMMA DI SERRAGGIO / CLAMPING RANGE	mm	0-125	80
SISTEMA DI SERRAGGIO A PUNTO ZERO / ZERO POINT CLAMPING SYSTEM	mm	□ 52	70
DIAMETRO DEL BULLONE A PUNTO ZERO / ZERO POINT BOLT DIAMETER	mm	Ø 16	60
COPPIA DI SERRAGGIO (MAX) / TIGHTENING TORQUE (MAX)	Nm	70	50
FORZA DI SERRAGGIO / CLAMPING FORCE	kN	14	40
PRECISIONE DI CENTRATURA / CENTRING ACCURACY	mm	± 0,02	30
			20
			10

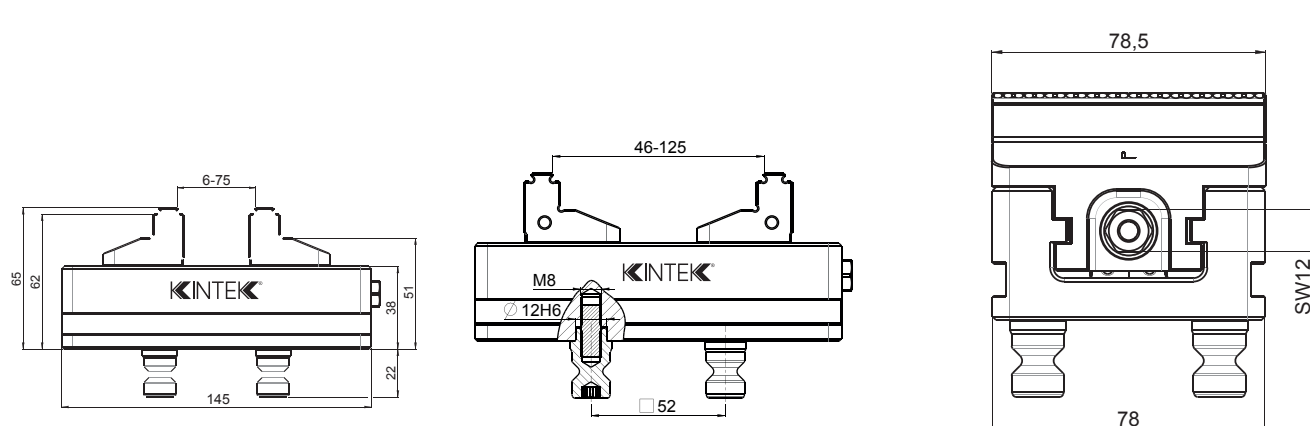
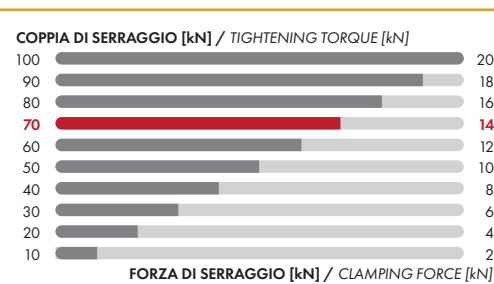

MORSA AUTOCENTRANTE A 5 ASSI MRC78 X 185

LA MORSA È ADATTA PER SISTEMI DI BLOCCAGGIO A PUNTO ZERO CON INTERASSE 52 MM. PUÒ ESSERE UTILIZZATA PER PARTICOLARI GREZZI CON GRIP 3 MM. E SUPERFICI LISCE CON GANASCE RETTIFICATE. LE GANASCE SONO REVERSIBILI E PERMETTONO DI RAGGIUNGERE UN CAMPO DI SERRAGGIO PIÙ AMPIO. DISPONIBILI ACCESSORI E RICAMBI.

5-AXIS CENTRING VICE MRC78 X 185

SUITABLE FOR ZERO POINT CLAMPING SYSTEMS WITH 52 GRID. CAN BE USED FOR PRE-PRESSED PARTS OR WITH SMOOTH SURFACES. REVERSIBLE JAWS. ACCESSORIES AND SPARE PARTS AVAILABLE. JAWS CAN BE REVERSED FOR A WIDER CLAMPING RANGE.

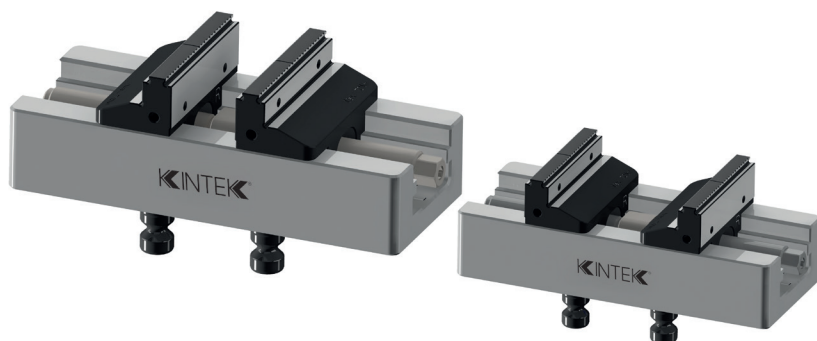

MRC78 X 185	PRICE	770,00	COPPIA DI SERRAGGIO [kN] / TIGHTENING TORQUE [kN]
LARGHEZZA GANASCE / JAW WIDTH	mm	78,5	100 20
LUNGHEZZA CORPO / BODY LENGTH	mm	185	90 18
GAMMA DI SERRAGGIO / CLAMPING RANGE	mm	0-165	80 16
SISTEMA DI SERRAGGIO A PUNTO ZERO / ZERO POINT CLAMPING SYSTEM	mm	□ 52	70 14
DIAMETRO DEL BULLONE A PUNTO ZERO / ZERO POINT BOLT DIAMETER	mm	Ø 16	60 12
COPPIA DI SERRAGGIO (MAX) / TIGHTENING TORQUE (MAX)	Nm	70	40 10
FORZA DI SERRAGGIO / CLAMPING FORCE	kN	14	30 6
PRECISIONE DI CENTRATURA / CENTRING ACCURACY	mm	± 0,02	20 4
			10 2

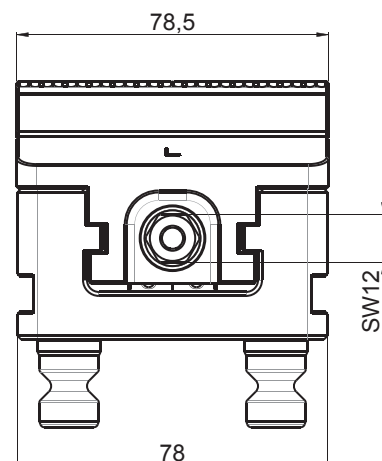
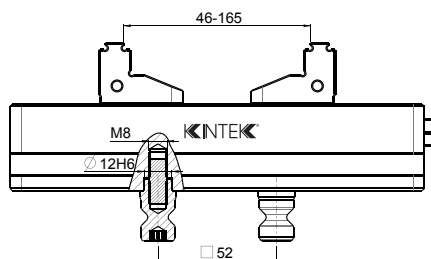
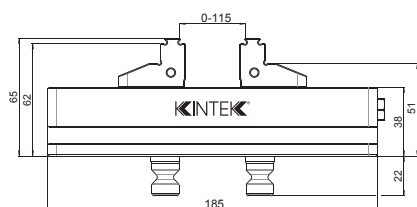

MORSA AUTOCENTRANTE A 5 ASSI MRC126 X 180

LA MORSA È ADATTA PER SISTEMI DI BLOCCAGGIO A PUNTO ZERO CON INTERASSE 96 MM. PUÒ ESSERE UTILIZZATA PER PARTICOLARI GREZZI CON GRIP 3 MM. E SUPERFICI LISCE CON GANASCIA RETTIFICATA. LE GANASCE SONO REVERSIBILI E PERMETTONO DI RAGGIUNGERE UN CAMPO DI SERRAGGIO PIÙ AMPIO. DISPONIBILI ACCESSORI E RICAMBI.

5-AXIS CENTRING VICE MRC126 X 180

SUITABLE FOR ZERO POINT CLAMPING SYSTEMS WITH 96 GRID. CAN BE USED FOR PRE-PRESSED PARTS OR WITH SMOOTH SURFACES. REVERSIBLE JAWS. ACCESSORIES AND SPARE PARTS AVAILABLE. JAWS CAN BE REVERSED FOR A WIDER CLAMPING RANGE.



MRC126 X 180	PRICE	869,00	COPPIA DI SERRAGGIO [kN] / TIGHTENING TORQUE [kN]
LARGHEZZA GANASCE / JAW WIDTH	mm	126,5	100
LUNGHEZZA CORPO / BODY LENGTH	mm	180	90
GAMMA DI SERRAGGIO / CLAMPING RANGE	mm	0-155	80
SISTEMA DI SERRAGGIO A PUNTO ZERO / ZERO POINT CLAMPING SYSTEM	mm	□ 96	70
DIAMETRO DEL BULLONE A PUNTO ZERO / ZERO POINT BOLT DIAMETER	mm	Ø 20	60
COPPIA DI SERRAGGIO (MAX) / TIGHTENING TORQUE (MAX)	Nm	100	50
FORZA DI SERRAGGIO / CLAMPING FORCE	kN	20	40
PRECISIONE DI CENTRATURA / CENTRING ACCURACY	mm	± 0,02	30
			20
			10

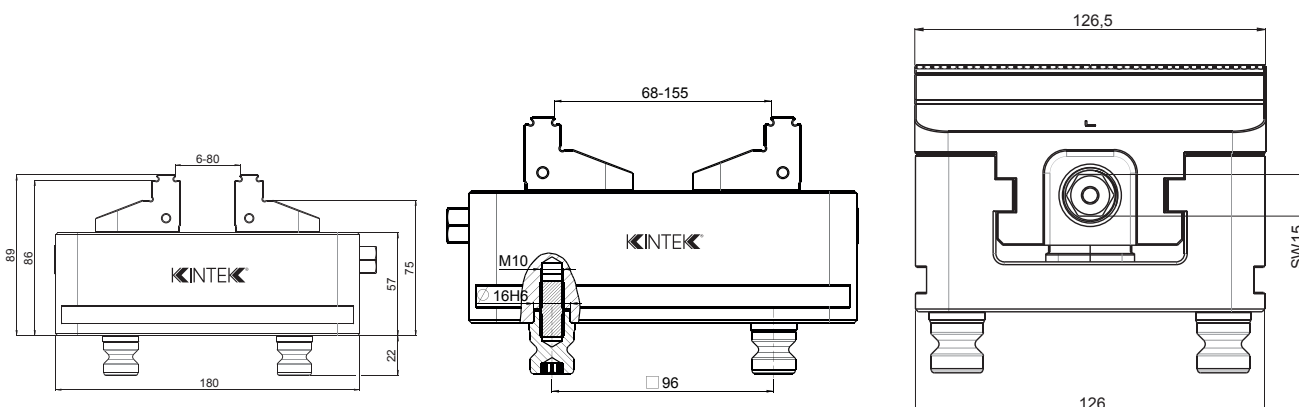
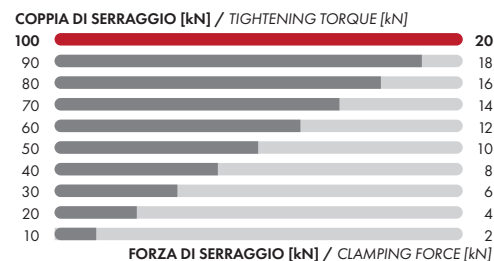

MORSA AUTOCENTRANTE A 5 ASSI MRC126 X 230

LA MORSA È ADATTA PER SISTEMI DI BLOCCAGGIO A PUNTO ZERO CON INTERASSE 96 MM. PUÒ ESSERE UTILIZZATA PER PARTICOLARI GREZZI CON GRIP 3 MM. E SUPERFICI LISCE CON GANASCIA RETTIFICATA. LE GANASCE SONO REVERSIBILI E PERMETTONO DI RAGGIUNGERE UN CAMPO DI SERRAGGIO PIÙ AMPIO. DISPONIBILI ACCESSORI E RICAMBI.

5-AXIS CENTRING VICE MRC126 X 230

SUITABLE FOR ZERO POINT CLAMPING SYSTEMS WITH 96 GRID. CAN BE USED FOR PRE-PRESSED PARTS OR WITH SMOOTH SURFACES. REVERSIBLE JAWS. ACCESSORIES AND SPARE PARTS AVAILABLE. JAWS CAN BE REVERSED FOR A WIDER CLAMPING RANGE.



MRC126 X 230	PRICE	1.027,00	COPPIA DI SERRAGGIO [kN] / TIGHTENING TORQUE [kN]
LARGHEZZA GANASCE / JAW WIDTH	mm	126,5	100
LUNGHEZZA CORPO / BODY LENGTH	mm	230	90
GAMMA DI SERRAGGIO / CLAMPING RANGE	mm	0-205	80
SISTEMA DI SERRAGGIO A PUNTO ZERO / ZERO POINT CLAMPING SYSTEM	mm	□ 96	70
DIAMETRO DEL BULLONE A PUNTO ZERO / ZERO POINT BOLT DIAMETER	mm	Ø 20	60
COPPIA DI SERRAGGIO (MAX) / TIGHTENING TORQUE (MAX)	Nm	100	50
FORZA DI SERRAGGIO / CLAMPING FORCE	kN	20	40
PRECISIONE DI CENTRATURA / CENTRING ACCURACY	mm	± 0,02	30
			20
			10

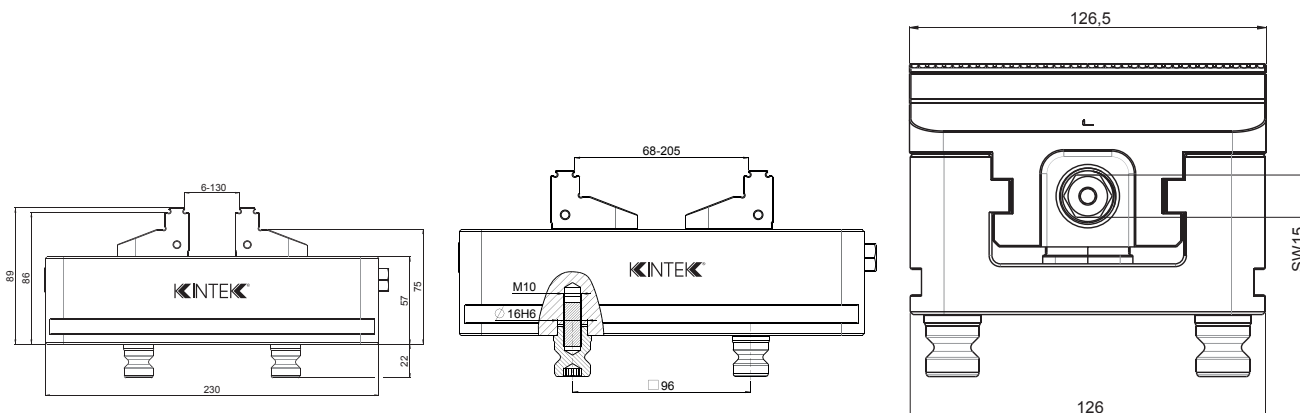
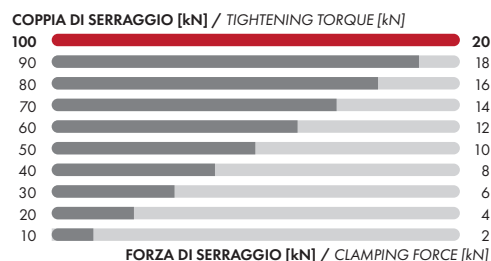

MORSA AUTOCENTRANTE A 5 ASSI MRC126 X 280

LA MORSA È ADATTA PER SISTEMI DI BLOCCAGGIO A PUNTO ZERO CON INTERASSE 96 MM. PUÒ ESSERE UTILIZZATA PER PARTICOLARI GREZZI CON GRIP 3 MM. E SUPERFICI LISCE CON GANASCE RETTIFICATE. LE GANASCE SONO REVERSIBILI E PERMETTONO DI RAGGIUNGERE UN CAMPO DI SERRAGGIO PIÙ AMPIO. DISPONIBILI ACCESSORI E RICAMBI.

5-AXIS CENTRING VICE MRC126 X 280

SUITABLE FOR ZERO POINT CLAMPING SYSTEMS WITH 96 GRID. CAN BE USED FOR PRE-PRESSED PARTS OR WITH SMOOTH SURFACES. REVERSIBLE JAWS. ACCESSORIES AND SPARE PARTS AVAILABLE. JAWS CAN BE REVERSED FOR A WIDER CLAMPING RANGE.



MRC126 X 280	PRICE	1.304,00	COPPIA DI SERRAGGIO [kN] / TIGHTENING TORQUE [kN]
LARGHEZZA GANASCE / JAW WIDTH	mm	126,5	100 20
LUNGHEZZA CORPO / BODY LENGTH	mm	280	90 18
GAMMA DI SERRAGGIO / CLAMPING RANGE	mm	0-255	80 16
SISTEMA DI SERRAGGIO A PUNTO ZERO / ZERO POINT CLAMPING SYSTEM	mm	□96	70 14
DIAMETRO DEL BULLONE A PUNTO ZERO / ZERO POINT BOLT DIAMETER	mm	Ø 20	60 12
COPPIA DI SERRAGGIO (MAX) / TIGHTENING TORQUE (MAX)	Nm	100	50 10
FORZA DI SERRAGGIO / CLAMPING FORCE	kN	20	40 8
PRECISIONE DI CENTRATURA / CENTRING ACCURACY	mm	± 0,02	30 6
			20 4
			10 2

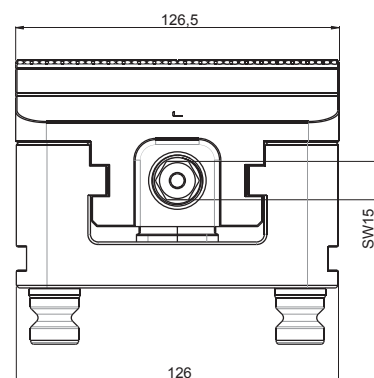
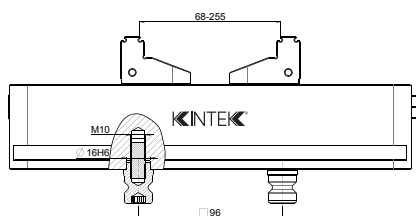
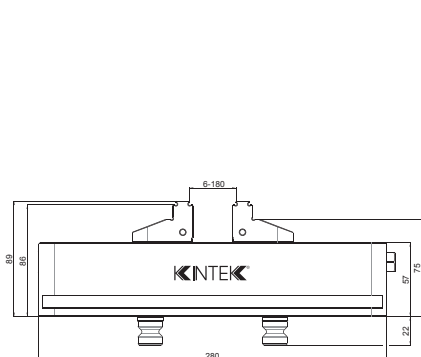
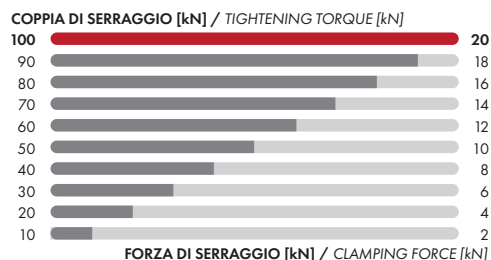

PUNTO ZERO ZK1

RIPETIBILITÀ NEL CENTESIMO.
FORI PER PERNI DI CENTRATURA CON INTERASSI 52 E 96. IL CORPO È IN ACCIAIO E NICHELATO IN SUPERFICIE.

ZERO POINT PLATES ZK1

REPETABILITY LESS THAN 10µm. INDUSTRY STANDARD 52 AND 96 CENTRING PINS SPACING IN ONE PLATE. SURFACE TREATED STEEL BODY CONSTRUCTION.



ZK1	PRICE	830,00	MKS	MKC
DIMENSIONI / DIMENSIONS	mm	196x176x27	KIT DI MONTAGGIO DISPONIBILI AVAILABLE MOUNTING KITS	
SISTEMA PUNTO ZERO / ZERO POINT SYSTEM	mm	□ 96 / 52		
TASTO PUNTO ZERO / ZERO POINT BOLTS	mm	∅ 20 / 16		
COPPIA DI SERRAGGIO MASSIMA / MAX TIGHTENING TORQUE	Nm	45		
FORZA DI MANTENIMENTO / HOLDING FORCE	kN	60		
PRECISIONE / ACCURACY	mm	0,01		
MORSA ADATTA / SUITABLE VICE	-	MRC126/MRC78/MRC48		
KIT DI MONTAGGIO ADATTO / SUITABLE MOUNTING KIT	-	MKS / MKS		

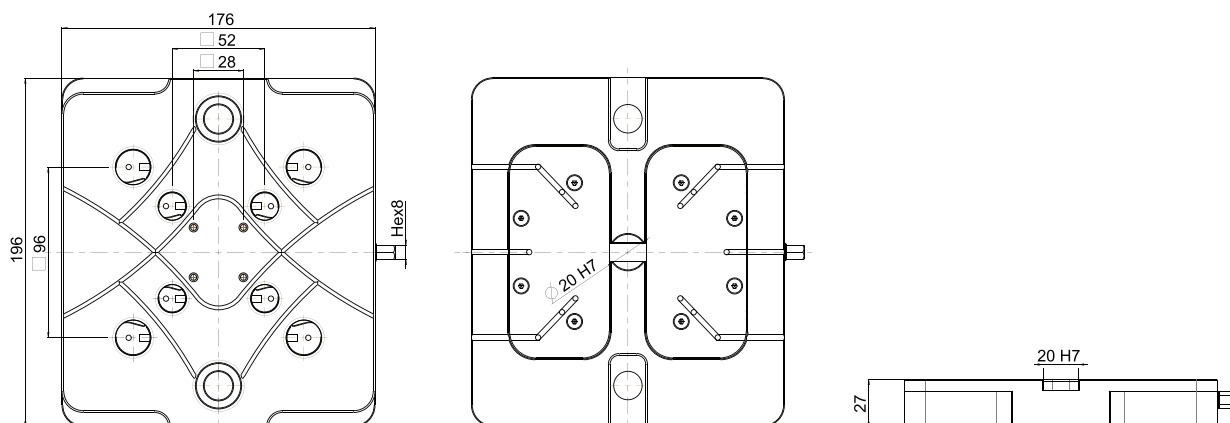

PUNTO ZERO ZK2

RIPETIBILITÀ NEL CENTESIMO.

FORI PER PERNI DI CENTRATURA CON INTERASSI 52 E 96. IL CORPO È IN ACCIAIO E NICHELATO IN SUPERFICIE.

ZERO POINT PLATES ZK2

REPETABILITY LESS THAN 10 μ m. INDUSTRY STANDARD 52 AND 96 CENTRING PINS SPACING IN ONE PLATE. SURFACE TREATED STEEL BODY CONSTRUCTION.



ZK2	PRICE	711,00	MKB
DIMENSIONI / DIMENSIONS	mm	176x146x27	KIT DI MONTAGGIO DISPONIBILI AVAILABLE MOUNTING KITS
SISTEMA PUNTO ZERO / ZERO POINT SYSTEM	mm	□ 96 / 52	
TASTO PUNTO ZERO / ZERO POINT BOLTS	mm	∅ 20 / 16	 POSIZIONAMENTO DI ALTA PRECISIONE GRAZIE AI FORI ∅13H7 E ALLE BOCCOLE DEL KIT DI MONTAGGIO MKB.
COPPIA DI SERRAGGIO MASSIMA / MAX TIGHTENING TORQUE	Nm	45	
FORZA DI MANTENIMENTO / HOLDING FORCE	kN	60	HIGH PRECISION POSITIONING DUE TO THE ∅13H7 HOLES AND THE BUSHINGS FROM THE MKB MOUNTING KIT.
PRECISIONE / ACCURACY	mm	0,01	
MORSA ADATTA / SUITABLE VICE	-	MRC126/MRC78/MRC48	
KIT DI MONTAGGIO ADATTO / SUITABLE MOUNTING KIT	-	MKB	

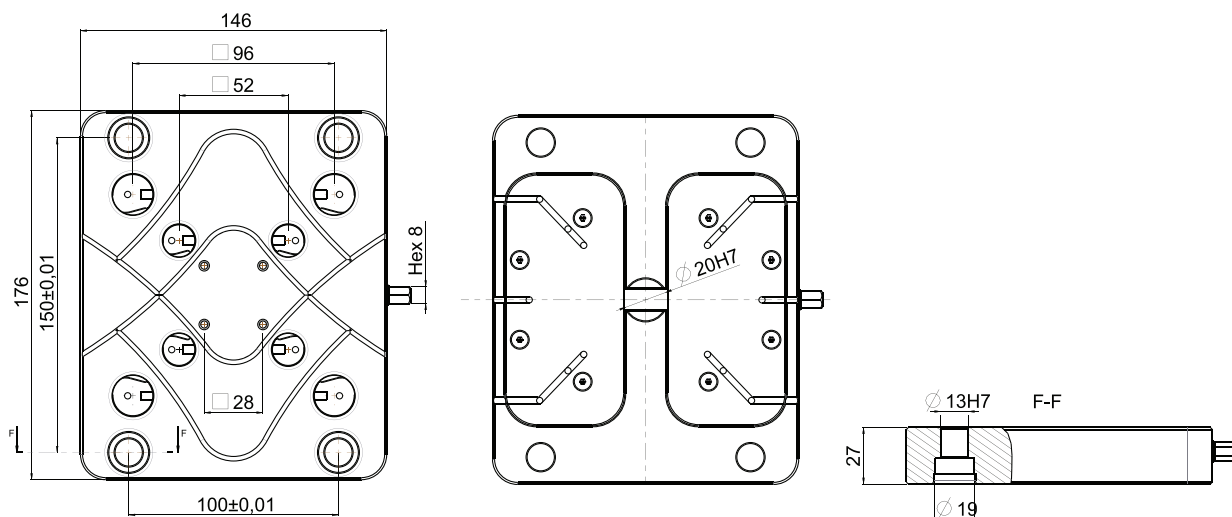

PUNTO ZERO ZK3

RIPETIBILITÀ NEL CENTESIMO.
FORI PER PERNI DI CENTRAGGIO CON INTERASSI DA 52 MM. IL CORPO È IN ACCIAIO E NICHELATO IN SUPERFICIE.

ZERO POINT PLATES ZK3

REPETABILITY LESS THAN 10 μ m. INDUSTRY STANDARD 52 CENTRING PINS SPACING. SURFACE TREATED STEEL BODY CONSTRUCTION.
SUITABLE FOR USE ON MILLING CENTERS TOWERS.



ZK3	PRICE	363,00	MKB
DIMENSIONI / DIMENSIONS	mm	104x104x27	KIT DI MONTAGGIO DISPONIBILI AVAILABLE MOUNTING KITS  POSIZIONAMENTO DI ALTA PRECISIONE GRAZIE AI FORI Ø13H7 E ALLE BOCCOLE DEL KIT DI MONTAGGIO MKB. HIGH PRECISION POSITIONING DUE TO THE Ø13H7 HOLES AND THE BUSHINGS FROM THE MKB MOUNTING KIT.
SISTEMA PUNTO ZERO / ZERO POINT SYSTEM	mm	□ 52	
TASTO PUNTO ZERO / ZERO POINT BOLTS	mm	Ø 16	
COPPIA DI SERRAGGIO MASSIMA / MAX TIGHTENING TORQUE	Nm	45	
FORZA DI MANTENIMENTO / HOLDING FORCE	kN	60	
PRECISIONE / ACCURACY	mm	0,01	
MORSA ADATTA / SUITABLE VICE	-	MRC78/MRC48	
KIT DI MONTAGGIO ADATTO / SUITABLE MOUNTING KIT	-	MKB	

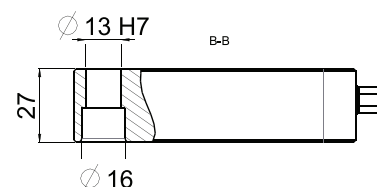
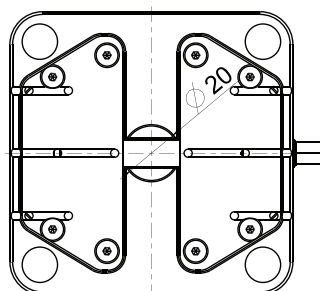
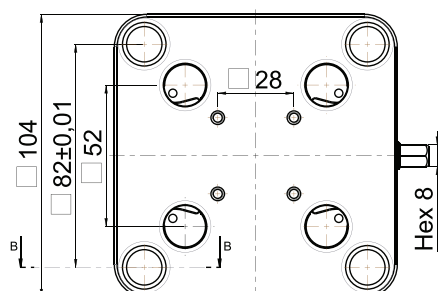

PUNTO ZERO ZK4 X 195

RIPETIBILITÀ NEL CENTESIMO.

FORI PER PERNI DI CENTRATURA CON INTERASSI 52 E 96. IL CORPO È IN ACCIAIO E NICHELATO IN SUPERFICIE.

ZERO POINT PLATES ZK4 X 195

REPETABILITY LESS THAN 10 μ m. INDUSTRY STANDARD 52 AND 96 CENTRING PINS SPACING IN ONE PLATE. SURFACE TREATED STEEL BODY CONSTRUCTION.

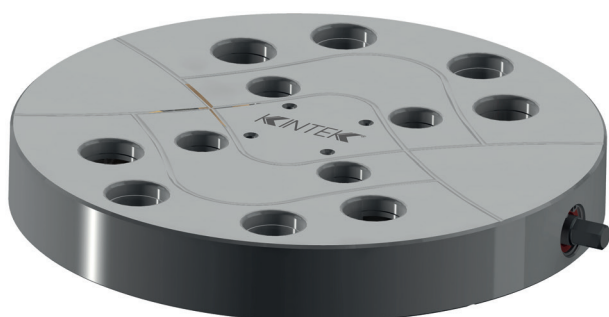

NEW

ZK4 X 195	PRICE	897,00	MKB
DIMENSIONI / DIMENSIONS	mm	195 / 27	KIT DI MONTAGGIO DISPONIBILI AVAILABLE MOUNTING KITS
SISTEMA PUNTO ZERO / ZERO POINT SYSTEM	mm	□ 96 / 52	
TASTO PUNTO ZERO / ZERO POINT BOLTS	mm	∅ 20 / 16	 POSIZIONAMENTO DI ALTA PRECISIONE GRAZIE AI FORI ∅13H7 E ALLE BOCCOLE DEL KIT DI MONTAGGIO MKB.
COPPIA DI SERRAGGIO MASSIMA / MAX TIGHTENING TORQUE	Nm	45	
FORZA DI MANTENIMENTO / HOLDING FORCE	kN	60	HIGH PRECISION POSITIONING DUE TO THE ∅13H7 HOLES AND THE BUSHINGS FROM THE MKB MOUNTING KIT.
PRECISIONE / ACCURACY	mm	0,01	
MORSA ADATTA / SUITABLE VICE	-	MRC126/MRC78/MRC48	
KIT DI MONTAGGIO ADATTO / SUITABLE MOUNTING KIT	-	MKB	

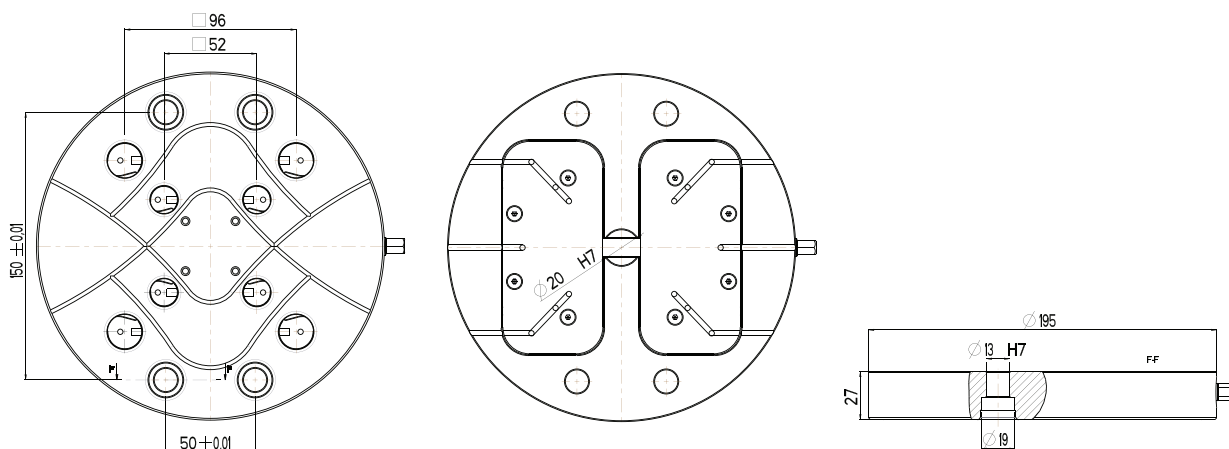

SERIE DI PINZE TIPO ER ER COLLET SETS



TYPE	PRICE	NUMERO DI PINZE NUMBER OF COLLETS	CAPACITÀ DI SERRAGGIO CLAMPING CAPACITY
SERIE - ER8	52,00	(1±5) 9 PINZE / COLLETS	Ø 1 - 1,5 - 2 - 2,5 - 3 - 3,5 - 4 - 4,5 - 6
SERIE - ER11	62,00	(1±7) 13 PINZE / COLLETS	Ø 1 - 1,5 - 2 - 2,5 - 3 - 3,5 - 4 - 4,5 - 5 - 5,5 - 6 - 6,5 - 7
SERIE - ER16	46,00	(1±10) 10 PINZE / COLLETS	Ø 1 - 2 - 3 - 4 - 5 - 6 - 7 - 8 - 9 - 10
SERIE - ER20	52,00	(2±13) 12 PINZE / COLLETS	Ø 2 - 3 - 4 - 5 - 6 - 7 - 8 - 9 - 10 - 11 - 12 - 13
SERIE - ER25	68,00	(2±16) 16 PINZE / COLLETS	Ø 2 - 3 - 4 - 5 - 6 - 7 - 8 - 9 - 10 - 11 - 12 - 13 - 14 - 15 - 16
SERIE - ER32	85,00	(3±20) 18 PINZE / COLLETS	Ø 3 - 4 - 5 - 6 - 7 - 8 - 9 - 10 - 11 - 12 - 13 - 14 - 15 - 16 - 17 - 18 - 19 - 20
SERIE - ER40	143,00	(4±26) 23 PINZE / COLLETS	Ø 4 - 5 - 6 - 7 - 8 - 9 - 10 - 11 - 12 - 13 - 14 - 15 - 16 - 17 - 18 - 19 - 20 - 21 - 22 - 23 - 24 - 25 - 26

RUNOUT ≤ 0,010

PINZE A TENUTA MECCANICA DEL REFRIGERANTE AD ALTA PRSSIONE MAX 120BAR STEEL SEALED COLLETS FOR HIGH PRESSURE MAX 120BAR

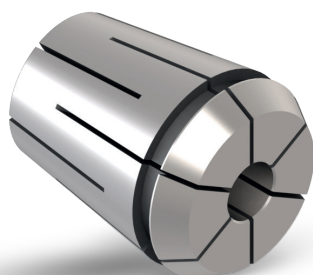

DIN6499/ISO 15488

TYPE	PRICE	NUMERO DI PINZE NUMBER OF COLLETS	PROGRESSIONE PROGRESSION
SERIE - ERC20	68,00	3±13	1
SERIE - ERC25	85,00	3±16	1
SERIE - ERC32	104,00	3±20	1

RUNOUT ≤ 0,010

CODOLI PER MANDRINI
TANKS FOR CHUCKS

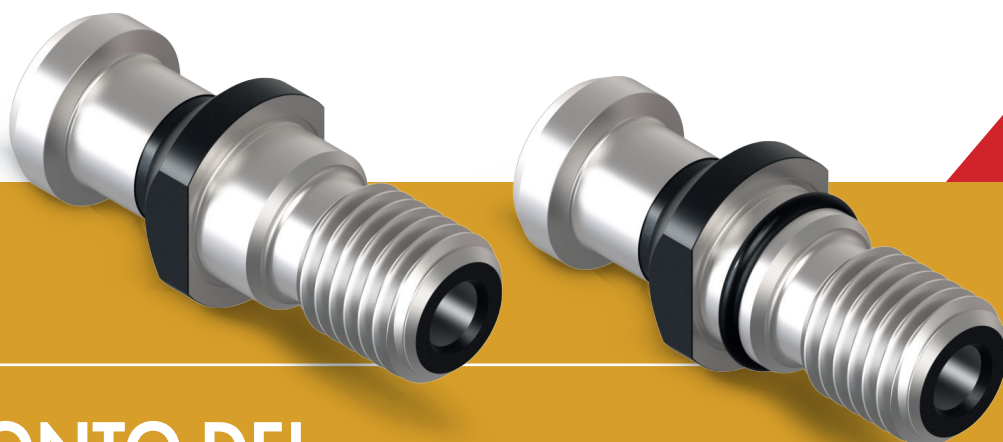

SCONTO DEL

50%

SU TUTTI I CODOLI
PRESENTI A CATALOGO.

È L'OCCASIONE PERFETTA PER AGGIORNARE I TUOI STRUMENTI CON
MANDRINI DI ALTA QUALITÀ A UN PREZZO IMBATTIBILE.

PER SAPERNE DI PIÙ, VISITA IL NOSTRO SITO WEB O CONTATTACI.

*DISCOUNT OF 50% ON ALL SHANKS PRESENT IN THE CATALOGUE.
THE PERFECT OPPORTUNITY TO RENEW YOUR TOOLS WITH HIGH QUALITY CHUCKS
AT AN UNBEATABLE PRICE.*

TO FIND OUT MORE, VISIT OUR WEBSITE.

MANDRINI A CALETTAMENTO
SHRINK FIT CHUCKS

SALES



SCONTO DEL
20%

SU TUTTI I MANDRINI
A CALETTAMENTO PRESENTI
A CATALOGO.

È L'OCCASIONE PERFETTA PER AGGIORNARE I TUOI STRUMENTI CON
MANDRINI DI ALTA QUALITÀ A UN PREZZO IMBATTIBILE.

PER SAPERNE DI PIÙ, VISITA IL NOSTRO SITO WEB O CONTATTACI.

*DISCOUNT OF 20% ON ALL SHRINK FIT CHUCKS PRESENT IN THE CATALOGUE.
THE PERFECT OPPORTUNITY TO RENEW YOUR TOOLS WITH HIGH QUALITY CHUCKS
AT AN UNBEATABLE PRICE.*

TO FIND OUT MORE, VISIT OUR WEBSITE.